

Features and Benefits

- Small size, low cost
- Easy to integrate
- Factory calibrated in wide temperature range:
-40...+125°C for sensor temperature and
-70...+380°C for object temperature.
- High accuracy of 0.5°C in a wide temperature range (0...+50°C for both Ta and To)
- High (medical) accuracy calibration
- Measurement resolution of 0.02°C
- Single and dual zone versions
- SMBus compatible digital interface
- Customizable PWM output for continuous reading
- Available in 3V and 5V versions
- Simple adaptation for 8...16V applications
- Sleep mode for reduced power consumption
- Different package options for applications and measurements versatility
- Automotive grade

Applications Examples

- High precision non-contact temperature measurements
- Thermal Comfort sensor for Mobile Air Conditioning control system
- Temperature sensing element for residential, commercial and industrial building air conditioning
- Windshield defogging
- Automotive blind angle detection
- Industrial temperature control of moving parts
- Temperature control in printers and copiers
- Home appliances with temperature control
- Healthcare
- Livestock monitoring
- Movement detection
- Multiple zone temperature control – up to 127 sensors can be read via common 2 wires
- Thermal relay / alert
- Body temperature measurement

Ordering Information

Part No.	Temperature Code	Package Code	- Option Code	Standard part	Packing form
			- X X X (1) (2) (3)		
MLX90614	E (-40°C...85°C) K (-40°C...125°C)	SF (TO-39)		-000	-TU

(1) Supply Voltage/ Accuracy A - 5V B - 3V C - Reserved D - 3V medical accuracy	(2) Number of thermopiles: A – single zone B – dual zone C – gradient compensated*	(3) Package options: A – Standard package B – Reserved C – 35° FOV D/E – Reserved F – 10° FOV G – Reserved H – 12° FOV (refractive lens) I – 5° FOV
---	---	---



Example:

MLX90614ESF-BAA-000-TU

* : See page 2

1 Functional diagram

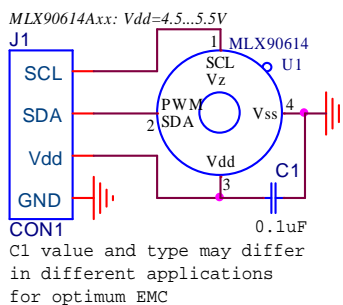

MLX90614 connection to SMBus

Figure 1: Typical application schematics

2 General Description

The MLX90614 is an Infra Red thermometer for non contact temperature measurements. Both the IR sensitive thermopile detector chip and the signal conditioning ASSP are integrated in the same TO-39 can.

Thanks to its low noise amplifier, 17-bit ADC and powerful DSP unit, a high accuracy and resolution of the thermometer is achieved.

The thermometer comes factory calibrated with a digital PWM and SMBus (System Management Bus) output.

As a standard, the 10-bit PWM is configured to continuously transmit the measured temperature in range of -20...120°C, with an output resolution of 0.14°C.

The factory default POR setting is SMBus.

General description (continued)

The MLX90614 is built from 2 chips developed and manufactured by Melexis:

- The Infra Red thermopile detector MLX81101
- The signal conditioning ASSP MLX90302, specially designed to process the output of IR sensor.

The device is available in an industry standard TO-39 package.

Thanks to the low noise amplifier, high resolution 17-bit ADC and powerful DSP unit of MLX90302 high accuracy and resolution of the thermometer is achieved. The calculated object and ambient temperatures are available in RAM of MLX90302 with resolution of 0.01°C. They are accessible by 2 wire serial SMBus compatible protocol (0.02°C resolution) or via 10-bit PWM (Pulse Width Modulated) output of the device.

The MLX90614 is factory calibrated in wide temperature ranges: -40...125°C for the ambient temperature and -70...380°C for the object temperature.

The measured value is the average temperature of all objects in the Field Of View of the sensor. The MLX90614 offers a standard accuracy of $\pm 0.5^\circ\text{C}$ around room temperatures. A special version for medical applications exists offering an accuracy of $\pm 0.2^\circ\text{C}$ in a limited temperature range around the human body temperature.

It is very important for the application designer to understand that these accuracies are only guaranteed and achievable when the sensor is in thermal equilibrium and under isothermal conditions (there are no temperature differences across the sensor package). The accuracy of the thermometer can be influenced by temperature differences in the package induced by causes like (among others): Hot electronics behind the sensor, heaters/coolers behind or beside the sensor or by a hot/cold object very close to the sensor that not only heats the sensing element in the thermometer but also the thermometer package.

This effect is especially relevant for thermometers with a small FOV like the xxC and xxF as the energy received by the sensor from the object is reduced. Therefore, Melexis has introduced the xCx version of the MLX90614. In these MLX90614xCx, the thermal gradients are measured internally and the measured temperature is compensated for them. In this way, the xCx version of the MLX90614 is much less sensitive to thermal gradients, but the effect is not totally eliminated. It is therefore important to avoid the causes of thermal gradients as much as possible or to shield the sensor from them.

As a standard, the MLX90614 is calibrated for an object emissivity of 1. It can be easily customized by the customer for any other emissivity in the range 0.1...1.0 without the need of recalibration with a black body.

The 10-bit PWM is as a standard configured to transmit continuously the measured object temperature for an object temperature range of -20...120°C with an output resolution of 0.14°C. The PWM can be easily customized for virtually any range desired by the customer by changing the content of 2 EEPROM cells. This has no effect on the factory calibration of the device.

The PWM pin can also be configured to act as a thermal relay (input is T_o), thus allowing for an easy and cost effective implementation in thermostats or temperature (freezing / boiling) alert applications. The temperature threshold is user programmable. In a SMBus system this feature can act as a processor interrupt that can trigger reading all slaves on the bus and to determine the precise condition.

The thermometer is available in 2 supply voltage options: 5V compatible or 3V (battery) compatible. The 5V can be easily adopted to operate from a higher supply voltage (8...16V, for example) by use of few external components (refer to "Applications information" section for details).

An optical filter (long-wave pass) that cuts off the visible and near infra-red radiant flux is integrated in the package to provide ambient and sunlight immunity. The wavelength pass band of this optical filter is from 5.5 till 14 μm (except for xCH and xCI type of devices which incorporate uncoated silicon lens).

3 Table of Contents

1 Functional diagram	1
2 General Description	1
3 Table of Contents	3
4 Glossary of Terms	4
5 Maximum ratings	4
6 Pin definitions and descriptions	5
7 Electrical Specifications	6
7.1 MLX90614Axx	6
7.2 MLX90614Bxx, MLX90614Dxx	8
8 Detailed description	10
8.1 Block diagram	10
8.2 Signal processing principle	10
8.3 Block description	11
8.3.1 Amplifier	11
8.3.2 Supply regulator and POR	11
8.3.3 EEPROM	11
8.3.4 RAM	14
8.4 SMBus compatible 2-wire protocol	14
8.4.1 Functional description	14
8.4.2 Differences with the standard SMBus specification (reference [1])	15
8.4.3 Detailed description	15
8.4.4 Bit transfer	16
8.4.5 Commands	17
8.4.6 SMBus communication examples	17
8.4.7 Timing specification	18
8.4.8 Sleep Mode	19
8.4.9 MLX90614 SMBus specific remarks	20
8.5 PWM	21
8.5.1 Single PWM format	22
8.5.2 Extended PWM format	23
8.5.3 Customizing the temperature range for PWM output	24
8.6 Switching Between PWM / Thermal relay and SMBus communication	26
8.6.1 PWM is enabled	26
8.6.2 Request condition	26
8.6.3 PWM is disabled	26
8.7 Computation of ambient and object temperatures	27
8.7.1 Ambient temperature T_a	27
8.7.2 Object temperature T_o	27
8.7.3 Calculation flow	28
8.8 Thermal relay	30
9 Unique Features	31
10 Performance Graphs	32
10.1 Temperature accuracy of the MLX90614	32
10.1.1 Standard accuracy	32
10.1.2 Medical accuracy	33
10.1.3 Temperature reading dependence on V_{DD}	33
10.2 Field Of View (FOV)	35
11 Applications Information	39
11.1 Use of the MLX90614 thermometer in SMBus configuration	39
11.2 Use of multiple MLX90614s in SMBus configuration	39
11.3 PWM output operation	40
11.4 Thermal alert / thermostat	40
11.5 High voltage source operation	41
12 Application Comments	42
13 Standard information regarding manufacturability of Melexis products with different soldering processes	44
14 ESD Precautions	44
15 FAQ	45
16 Package Information	47
16.1 MLX90614xxA	47
16.2 MLX90614xCC	47
16.3 MLX90614xCF	48
16.4 MLX90614xCH	48
16.5 MLX90614xCI	49
16.6 Part marking	49
16.7 Operating and storage humidity range	49
17 Table of figures	50
18 References	51
19 Disclaimer	51

4 Glossary of Terms

PTAT	Proportional To Absolute Temperature sensor (package temperature)
POR	Power On Reset
HFO	High Frequency Oscillator (RC type)
DSP	Digital Signal Processing
FIR	Finite Impulse Response. Digital filter
IIR	Infinite Impulse Response. Digital filter
IR	Infra-Red
PWM	Pulse With Modulation
DC	Duty Cycle (of the PWM) ; Direct Current (for settled conditions specifications)
FOV	Field Of View
SDA,SCL	Serial DAta, Serial CLock – SMBus compatible communication pins
T _a	Ambient Temperature measured from the chip – (the package temperature)
T _o	Object Temperature, 'seen' from IR sensor
ESD	Electro-Static Discharge
EMC	Electro-Magnetic Compatibility
ASSP	Application Specific Standard Product
TBD	To Be Defined

Note: sometimes the MLX90614xxx is referred as “the module”.

5 Maximum ratings

Parameter	MLX90614ESF-Axx	MLX90614ESF-Bxx MLX90614ESF-Dxx	MLX90614KSF-Axx
Supply Voltage, V _{DD} (over voltage)	7V	5V	7V
Supply Voltage, V _{DD} (operating)	5.5 V	3.6V	5.5V
Reverse Voltage	0.4 V		
Operating Temperature Range, T _A	-40...+85°C		-40...+125°C
Storage Temperature Range, T _S	-40...+125°C		-40...+125°C
ESD Sensitivity (AEC Q100 002)	2kV		
DC current into SCL / Vz (Vz mode)	2 mA		
DC sink current, SDA / PWM pin	25 mA		
DC source current, SDA / PWM pin	25 mA		
DC clamp current, SDA / PWM pin	25 mA		
DC clamp current, SCL pin	25 mA		

Table 1: Absolute maximum ratings for MLX90614

Exceeding the absolute maximum ratings may cause permanent damage.
Exposure to absolute-maximum-rated conditions for extended periods may affect device reliability.

6 Pin definitions and descriptions

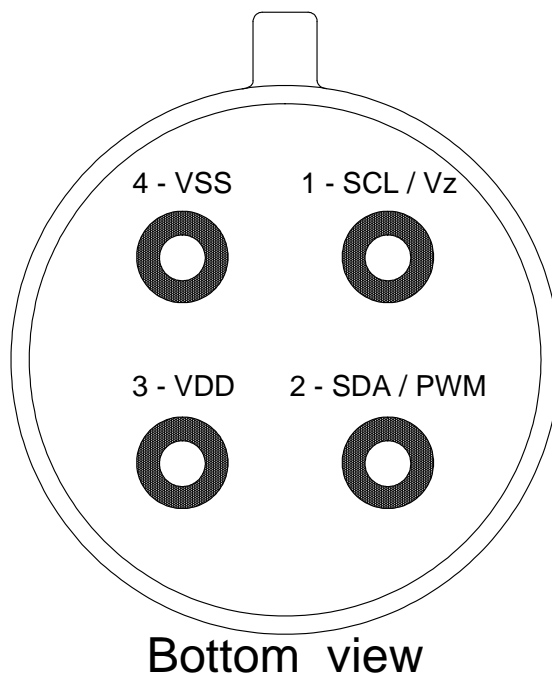

Figure 2: Pin description

Pin Name	Function
SCL / Vz	Serial clock input for 2 wire communications protocol. 5.7V zener is available at this pin for connection of external bipolar transistor to MLX90614Axx to supply the device from external 8 ...16V source.
SDA / PWM	Digital input / output. In normal mode the measured object temperature is available at this pin Pulse Width Modulated. In SMBus compatible mode the pin is automatically configured as open drain NMOS.
VDD	External supply voltage.
VSS	Ground. The metal can is also connected to this pin.

Table 2: Pin description MLX90614

Note: for +12V (+8...+16V) powered operation refer to the Application information section. For EMC and isothermal conditions reasons it is highly recommended not to use any electrical connection to the metal can except by the VSS pin.
With the SCL / Vz and PWM / SDA pins operated in 2-wire interface mode, the input Schmidt trigger function is automatically enabled.